

SAFETY FIRST:

If you are collecting the equipment for someone else please make sure this sheet is given to the equipment user to read. In accordance with Health and Safety in Employment Act requirements, this sheet should be given to the site supervisor if the equipment is being hired for use at a commercial worksite so that the information is available to all users.

Required Safety Equipment



Ear Muffs



Gloves



Boots



Protective Clothing



Visual Inspection

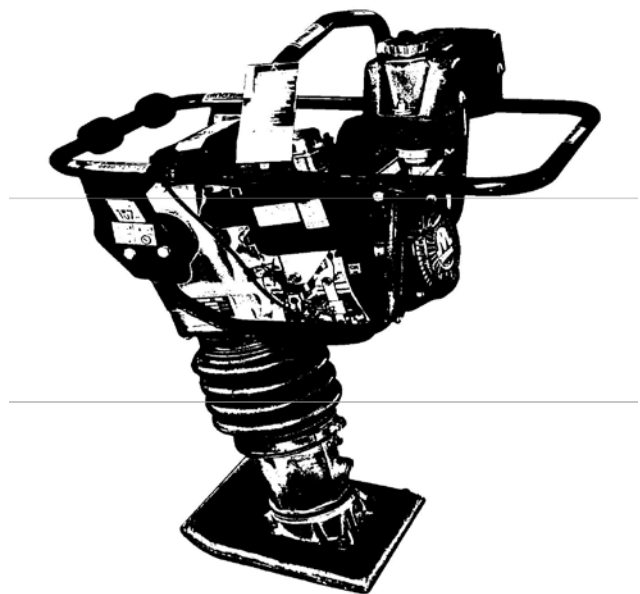

Pre Start Checks and Safety

- ! Check fuel tank is full (2 Stroke 25:1 mix)
- ! Check oil in compaction leg (sight glass on side of leg)
- ! Check for loose nuts, bolts, screws
- ! Use extreme caution and always be aware of ground subsidence with compaction vibration transfer
- ! Ensure there are no foreign objects (ie wire, steel, electrical cables, water pipes etc buried shallow)
- ! Keep children away from work area
- ! Hold rammer with both hands
- ! Make sure you have a firm footing when operating
- ! Do not spill fuel
- ! Do not allow inexperienced people to operate the machine
- ! Ensure hands, feet and loose clothing are kept clear from moving parts of the rammer
- ! Ensure the work area is clear of any obstacles, steep gradients or uneven ground

When Operating

- Hold rammer firmly with both hands
- Move throttle trigger to full throttle (NOTE: these units are not designed to run at part throttle)
- Proceed to steer rammer around area to be compacted

Starting procedure

- Turn ignition switch to ON position
- Turn fuel tap on (on some models)
- Place choke in ON position (Cold start)
- Move throttle lever to FULL throttle
- Pull starter cord with short sharp pulls until engine fires or starts
- Open choke as soon as engine fires or starts
- Restart engine if required (without choke)
- Move throttle lever to the idle position
- Allow engine to warm up

Stopping and After Use

- Idle engine
- Turn ignition switch to OFF
- Turn fuel tap off